

QY1164D

THREE-PHASE SYNCHRONOUS GENERATOR WINDING QY311 Datasheet for 4 poles -50Hz @ 1500rpm/ 60Hz @ 1800rpm

Ambient Temperature	40 °C	Method of Cooling	Air cooling
Temperature Rise	125 °C	Direction of Rotation	Clockwise
Insulation Class	H	Maximum Over-speed	2250r/min
Power Factor	0.8	Degree of Protection / Enclosure	IP23
Excitation	Brushless	Altitude	1000m
Winding Pitch	2/3	Stator winding	DLL
Pole	4	Number of Terminal	12
Duty	S1- Continuous	Rotor	With damping cage
Waveform	TIF<50		THF<2%
Waveform distortion	BS EN 61000-6-2&BS EN 61000-6-4,VDE 0875G,VDE0874N		
Radio interference	Noload<1.5%,Non-distorting balanced linear load<5%		
AVR MODEL AVR	Standard	Selection	
	SX460	AS440	KRS440
Voltage Regulation - in steady state condition	±1.0	±1.0	±1.0
Short Circuit Current Capacity	Control does not sustain a short circuit current		

Electrical Characteristic

Frequency	Hz	50				60			
Voltage (series star) Y	V	380/220	400/231	415/240	440/254	416/240	440/254	460/266	480/277
Voltage (parallel star) YY	V	190/110	200/115	208/120	220/127	208/120	220/127	230/133	240/138
Voltage (series delta) Δ	V	220	230	240	254	240	254	266	277
Rated power at Class H (125 °C) temperature rise	kVA	16	16	16	13.5	18.9	20	20	20
	kW	12.8	12.8	12.8	10.8	15.1	16.0	16.0	16.0
Efficiency at Class H (P.F.=0.8)	4/4%	81	81.8	82	82.6	81.1	81.3	82	82.5
	3/4%	84	84.1	84.4	84.7	84	84	84.5	84.8
	2/4%	85.1	85.1	85.1	85.1	85.1	85.2	85.3	85.3
Efficiency at Class H (P.F.=1.0)	4/4%	84.9	85.4	85.9	86.2	85	85	85.7	86
	3/4%	87.1	87.7	87.9	88	87.1	87.3	87.8	88
	2/4%	88.5	88.5	88.5	88.4	88.2	88.4	88.5	88.6

Reactances (%) at Class H

Direct axis synchronous reactance unsaturated	X _d	1.921	1.734	1.611	1.698	2.272	2.149	1.966	1.806
Direct axis transient reactance saturated	X' _d	0.196	0.177	0.164	0.173	0.231	0.219	0.2	0.184
Direct axis subtransient reactance saturated	X'' _d	0.123	0.111	0.103	0.109	0.146	0.138	0.126	0.116
Quadrature axis synchronous reactance unsaturated	X _q	0.954	0.861	0.8	0.844	1.129	1.068	0.977	0.897
Quadrature axis subtransient reactance saturated	X'' _q	0.22	0.199	0.185	0.194	0.26	0.246	0.225	0.207
Leakage reactance	X _l	0.078	0.07	0.065	0.068	0.092	0.087	0.079	0.073
Negative sequence reactance saturated	X ₂	0.184	0.166	0.154	0.162	0.218	0.206	0.188	0.173
Zero sequence reactance unsaturated	X ₀	0.083	0.075	0.07	0.073	0.098	0.093	0.085	0.078
Short-circuit ratio	K _{cc}	0.5206	0.5767	0.6207	0.5889	0.4401	0.4653	0.5086	0.5537

Short-circuit transient time constant (sec.)	T' _d	0.018							
Subtransient time constant (sec.)	T'' _d	0.0045							
Open circuit time constant (sec.)	T' _{do}	0.35							
Armature time constant (sec.)	T _a	0.0055							
Stator Winding Resistance (20°C)	ohm	0.645							
Rotor Winding Resistance (20°C)	ohm	0.56							
Exciter Stator Resistance (20°C)	ohm	19							
Exciter Rotor Phase resistance	ohm	0.13							
No load excitation current	i ₀ (A)	0.56	0.62	0.64	0.62	0.55	0.57	0.62	0.65
Full load excitation current	i _c (A)	1.95	1.9	1.95	1.9	1.88	1.9	1.92	1.92
Cooling air requirement	m ³ /sec	0.071m ³ /s 150cfm				0.09m ³ /s 191cfm			

Mechanical Characteristic

Configuration	Single Bearing	Double Bearing
Type of Construction	B2-SAE	IM B34
Total Weight - kgs	108	113
Weight wound stator - kgs	33	33
Weight wound rotor - kgs	33.72	34.5
Inertia (J) [kgm ²]	0.1278kgm ²	0.1279kgm ³
Drive end bearing / Lubrication		BALL.6309-2RS(ISO)
Non-drive end bearing / Lubrication	BALL.6306-2RS(ISO)	BALL.6306-3RS(ISO)
Packing crate size (cm)	49X45X58	58X45X57

QYI164D

Winding 311 / 0.8 Power Factor

RATINGS

Class - Temp Rise		Cont. F - 105/40°C				Cont. H - 125/40°C				Standby - 150/40°C				Standby - 163/27°C			
50 Hz	Series Star (V)	380	400	415	440	380	400	415	440	380	400	415	440	380	400	415	440
	Parallel Star (V)	190	200	208	220	190	200	208	220	190	200	208	220	190	200	208	220
	Series Delta (V)	220	230	240	254	220	230	240	254	220	230	240	254	220	230	240	254
	kVA	15.0	15.0	15.0	12.7	16.0	16.0	16.0	13.5	N/A	N/A						
kW	12.0	12.0	12.0	10.2	12.8	12.8	12.8	10.8									
Efficiency (%)	81.8	82.4	82.8	83.2	81.0	81.7	82.1	82.6									
kW Input	14.7	14.6	14.5	14.4	15.8	15.7	15.6	15.5									
60 Hz	Series Star (V)	416	440	460	480	416	440	460	480	416	440	460	480	416	440	460	480
	Parallel Star (V)	208	220	230	240	208	220	230	240	208	220	230	240	208	220	230	240
	Delta (V)	240	254	266	277	240	254	266	277	240	254	266	277	240	254	266	277
	kVA	17.8	18.8	18.8	18.8	18.9	20.0	20.0	20.0	N/A	N/A						
kW	14.2	15.0	15.0	15.0	15.1	16.0	16.0	16.0									
Efficiency (%)	82.0	82.2	82.7	83.2	81.3	81.4	82.0	82.5									
kW Input	17.4	18.3	18.2	18.1	18.6	19.7	19.5	19.4									

DIMENSIONS

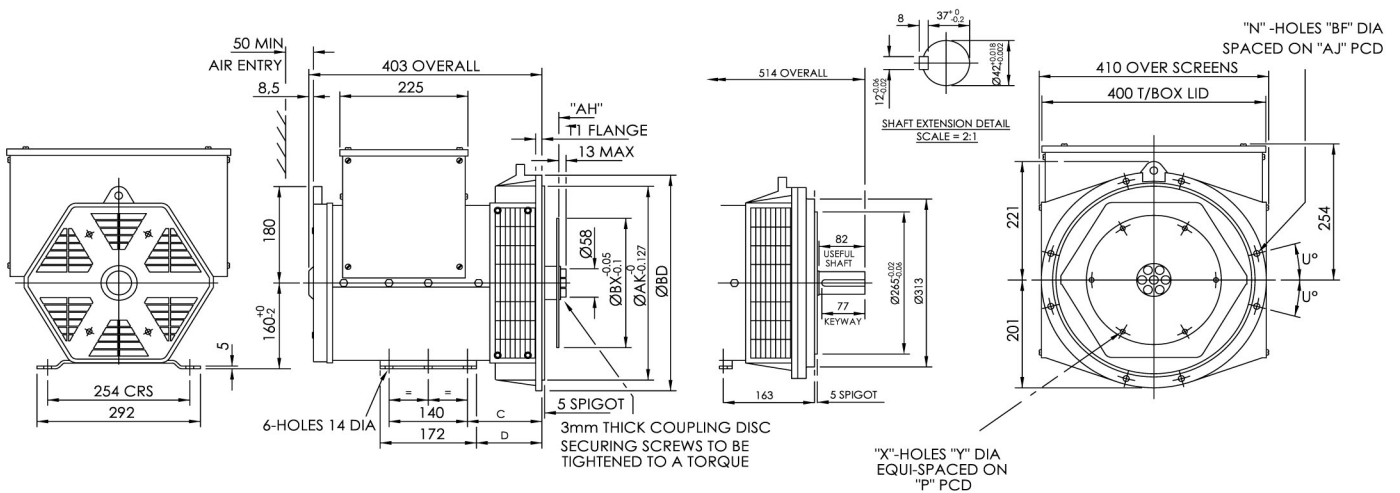

COUPLING DISC					
SAE	BX	P	X	Y	AH
11.5	352.42	333.38	8	11	39.6
10	314.32	295.28	8	11	53.8
8	263.52	244.48	6	11	62
7.5	241.3	222.25	8	9	30.2
6.5	215.9	200.02	6	9	30.2

FLANGE(mm)								
	BD	AK	AJ	U°	BF	n	C	D
SAE5	356	314.32	333.38	22.5	11	8	133	117
SAE4	402	361.95	381	15	11	8	133	117
SAE3	451	409.58	428.62	15	11	8	145	129
SAE2	489	447.68	466.72	15	11	12	172	156

VER	MOD	DRW	Date	QYI 164CD	1:1	QT002Z030.3
Design	APP					
CHK	Date	2016.01	G8/T1804-m	mm		

**50
Hz**

QYI164D
Winding 311

THREE PHASE EFFICIENCY CURVES

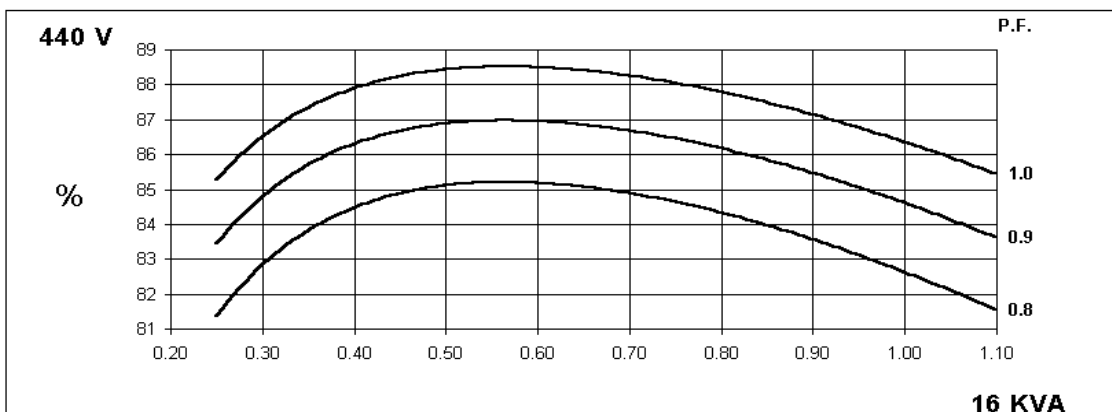
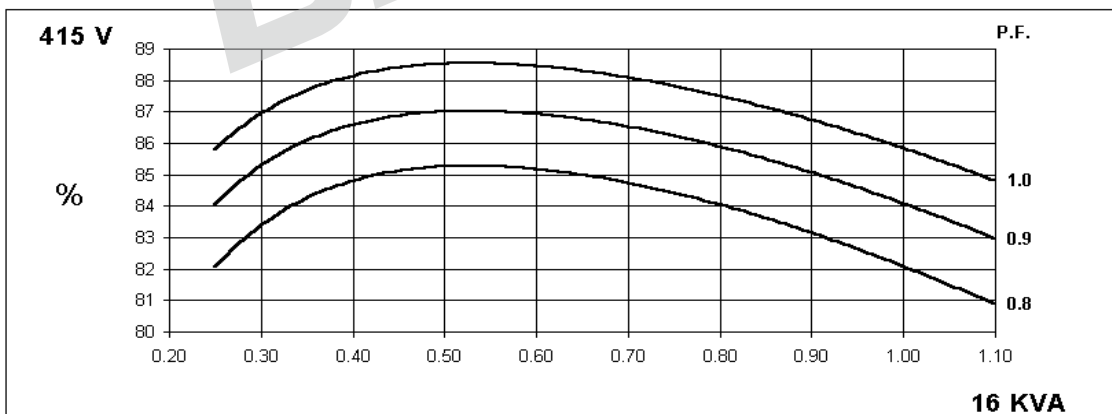
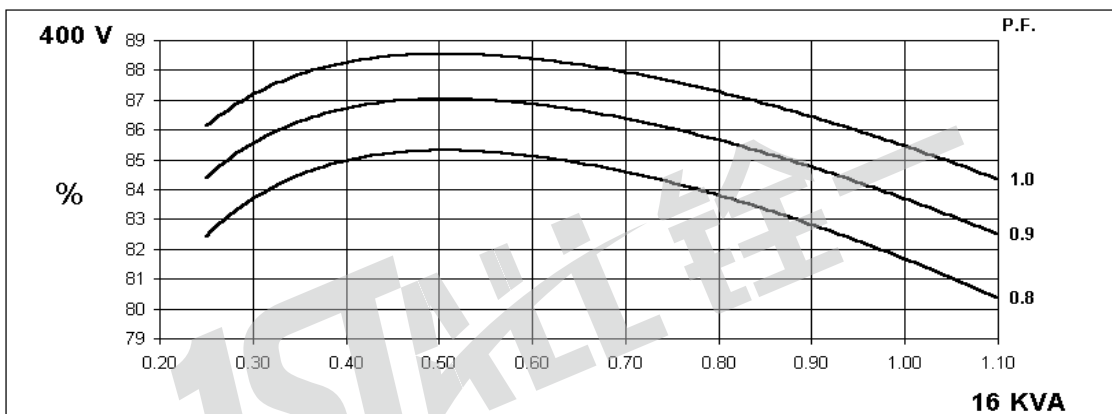
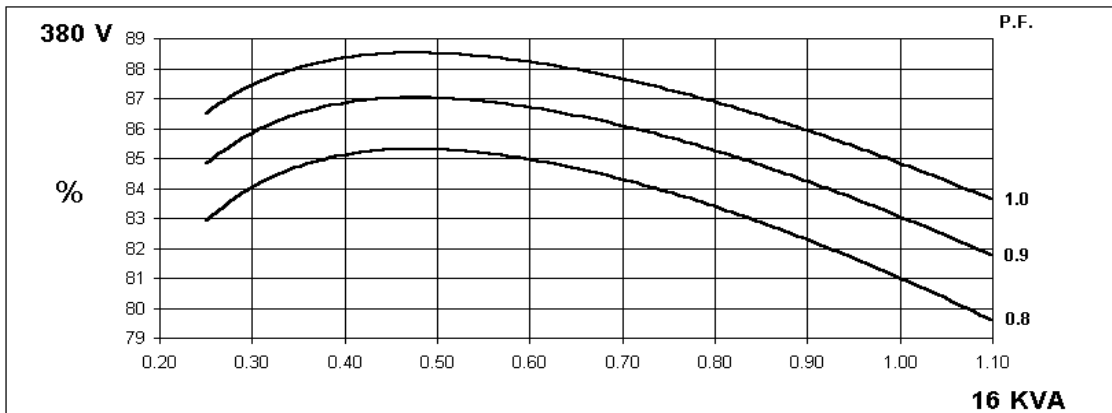

THREE PHASE EFFICIENCY CURVES

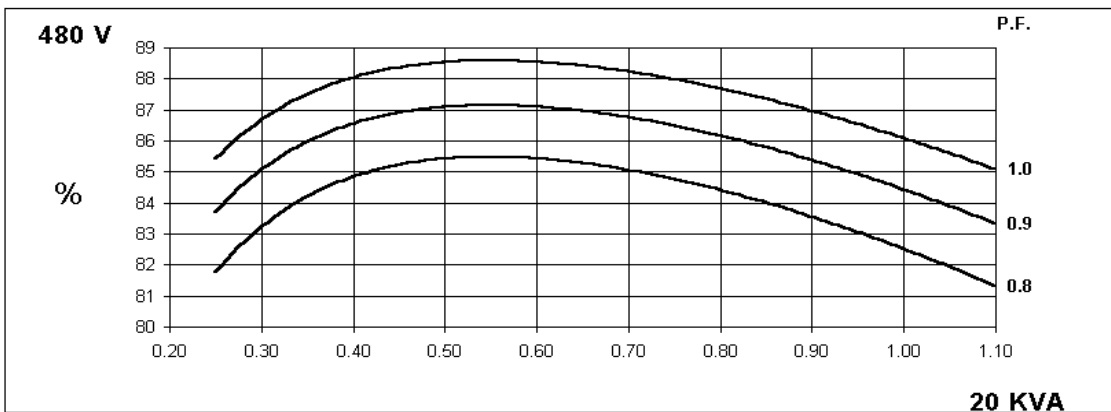
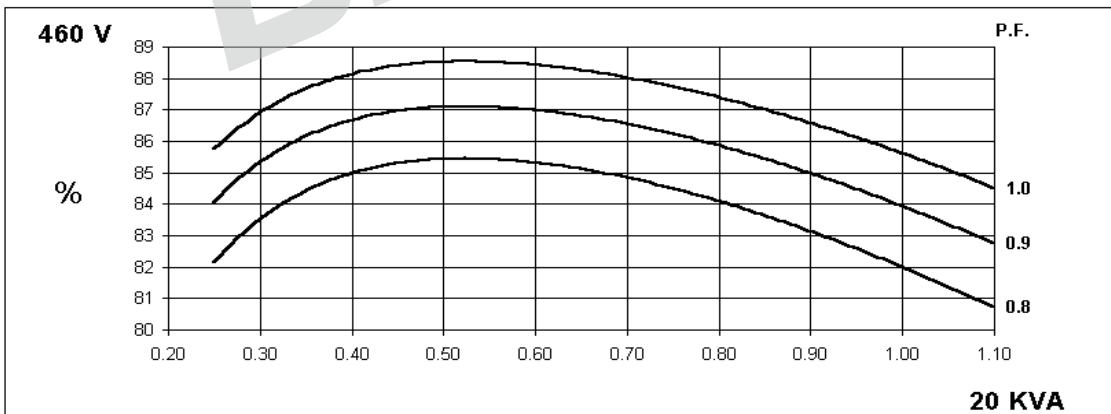
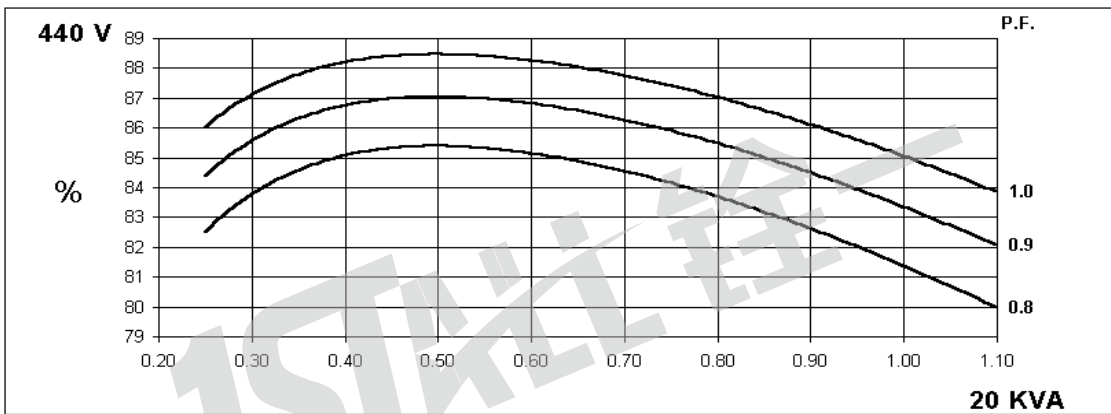
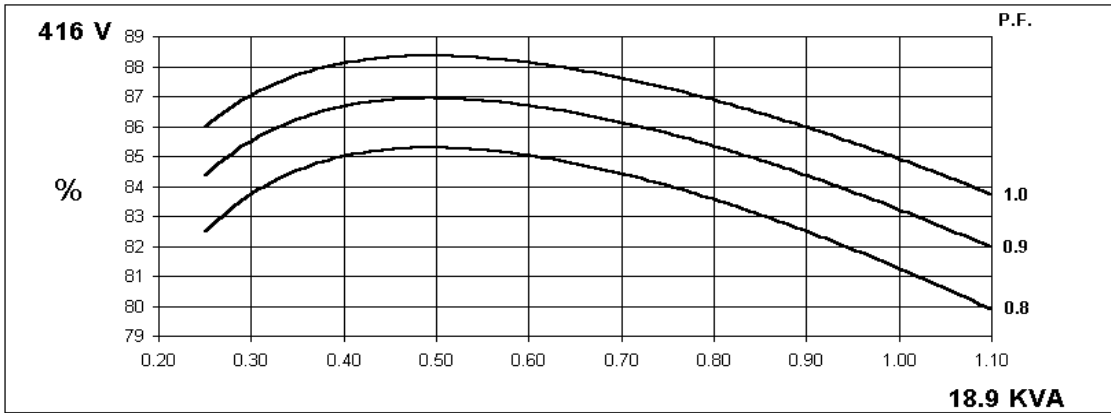

QYI164D

Winding 311

INERTIA

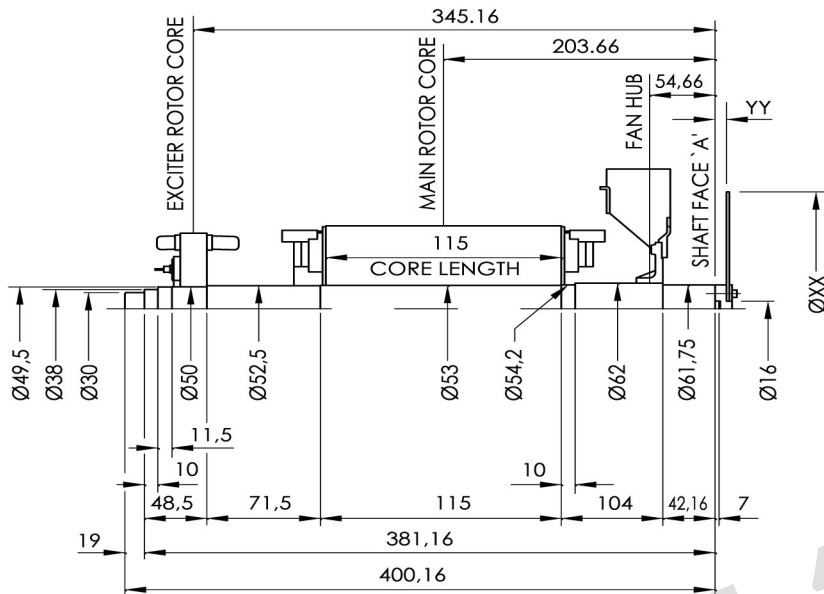

COMPONENT	Wt kg	J kgm ²
EX.ROTOR	4,300	0,0170
MAIN ROTOR	21,280	0,1018
FAN	0,744	0,0061
SHAFT	7,391	0,0029
TOTAL	33,715	0,1278

ADAPTOR	COUPLING	COUPLING DIMENSIONS		COUPLING ASSEMBLY WEIGHT	COUPLING DISC J
SAE No.	SAE No.	XX	YY	kg	kgm ²
6	7½	241,2	31,7	1,810	0,0078
4/5	7½	241,2	0	1,071	0,0078
4/5	8	263	31,7	2,018	0,0111
4	10	314	23,8	2,377	0,0225
3	10	314	35,8	2,657	0,0225
3	1½	352	21,5	2,793	0,0356

				QYI 164D	1:1	OQY201007
				INERTIA		
VER	MOD	DRW	Date			
Design		APP				
CHK		Date	2018.01			

WWW.FIRSTALLPOWER.COM

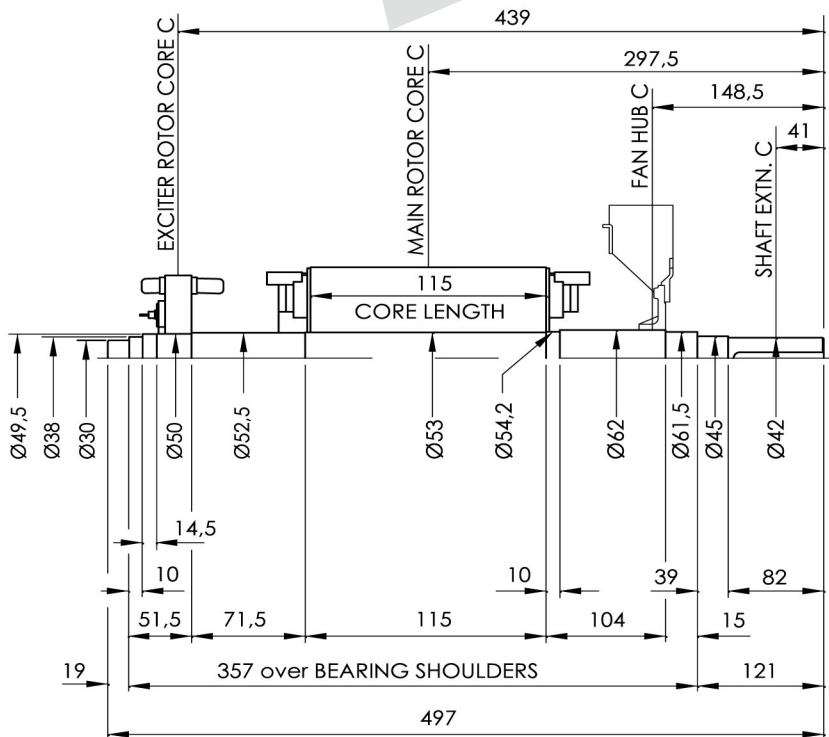

COMPONENT	Wt kg	J kgm ²
EX. ROTOR	4,300	0,0170
MAIN ROTOR	21,280	0,1018
FAN	0,744	0,0061
SHAFT	8,174	0,0030
TOTAL	34,498	0,1279

				QYI 164D	1:1	OQY201008
				INERTIA		
VER	MOD	DRW	Date			
Design		APP				
CHK		Date	2018.01			

WWW.FIRSTALLPOWER.COM